



Thailand's Official Distributor

AUBO-i3

Collaborative Lightweight Robot

Made for Human Centric
Agile Manufacturing

Versatile-Flexible-User Friendly
Low Cost-Lightweight



6 axis

3 Kg payload

625 mm reach



NRTAC

AUBO-i3

Collaborative Robot (Co-Bot)

AUBO Robots work closely within the human environment without the need for safety equipment, depending on risk assessment.

COLLABORATIVE FUNCTION:

- Hand guide-to-teach (inverse kinematics motion planning), this manual operation of the robot enables quick and easy programming by demonstration without any programming skills.
- Robot works side by side with human operator without safety fence, laser or sensors (after a risk assessment is performed).
- Teach pendant user interface for programming (forward kinematics) enables online programming and simulation via a touch screen tablet.
- Lightweight, flexible and easy to re-purpose this lightweight robot.

SAFETY FUNCTIONS:

- Designed in accordance with PL d and ISO 10218-1 (ISO/TS 15066) safety requirements and with most all specifications for collaborative robots operation.
- Power and force limiting design brings robot to a protective stop if limits are exceeded or a collision is detected. Speed and force can be adjusted to fit and optimize any application easily.
- Sensors embedded in motor drives provide real-time feedback to prevent dangerous situations.
- Emergency stop buttons are positioned on teach pendant and control box with a braking distance less than 1mm.

OPEN SOURCE ARCHITECTURE:

- CAN bus network used in this robot for multiple microcontrollers to communicate with each other.
- ROS (Robot Operating System) compatibility is supported through an API.
- Hardware adopts BUS protocols with open I/O interface extensions.
- Easily integrate robot into existing production systems.

RETURN ON INVESTMENT (ROI):

- Low cost of ownership without basic programming skills needed, and ease of integration into a system, all add up to a quick return on your investment.
- Short run, high mix environments like Lab automation or machine tending are prime examples of industries needing fast redeployment.
- Floor space is a premium cost at most companies—usually more than the equipment. A small foot print, lightweight robot will be a huge benefit for any size company's cost of production.
- Repurpose, redeploy and/or reinvent applications with the same robot, fast change over for lean manufacturing.
- Remove human error in a high-mix low-volume (HMLV), this reduces manufacturing time and consequently increases capacity; without adding costly resources so robot acts as a de facto quality inspector.

INTELLIGENCE:

- Vision systems can be easily integrated into controller.
- Control Box communication ports include TCP/IP, Modbus RTU/TCP, and USB 2.0
- This research robot platform is used widely around the world in corporate labs and for academic robotics research.

AUBO-i3 Collaborative Robot (Co-Bot)

Work Envelope-Range of Motion of the Point P

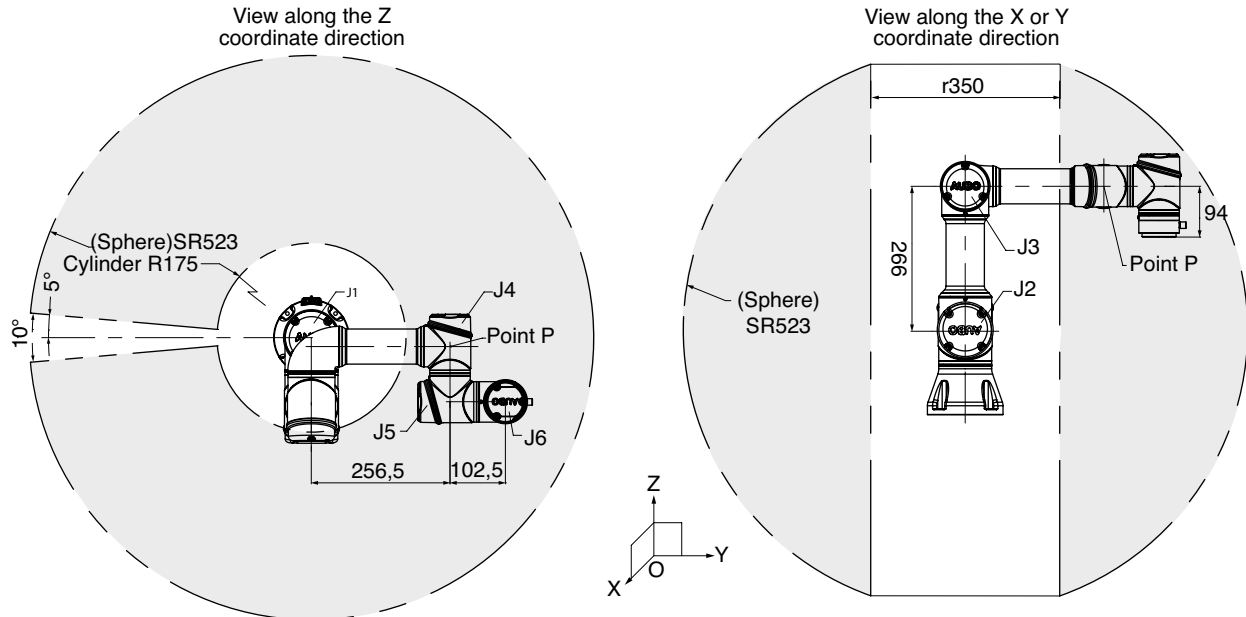

NOTE:

1. Double dotted _____ line means regional boundaries
2. The trajectory of Point P may exceed the space area which contained by the double dotted line

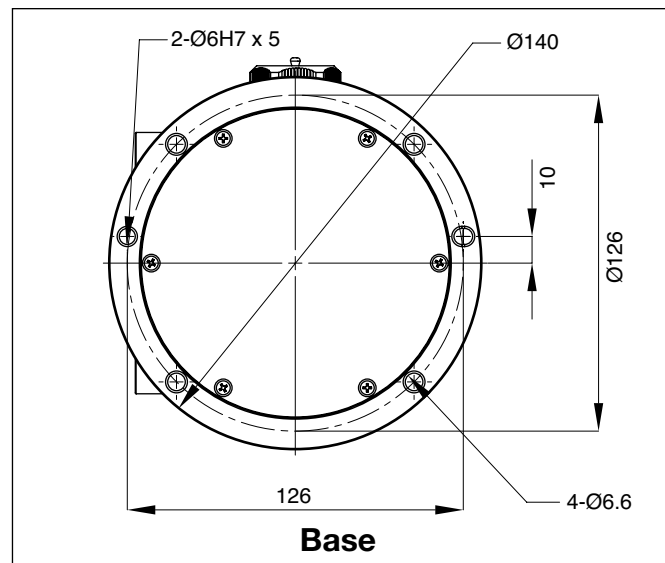
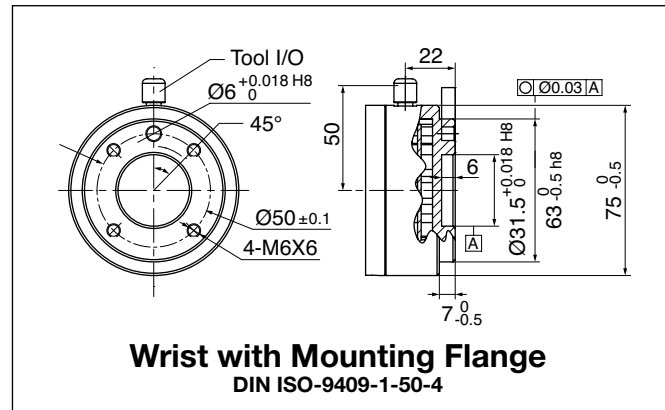
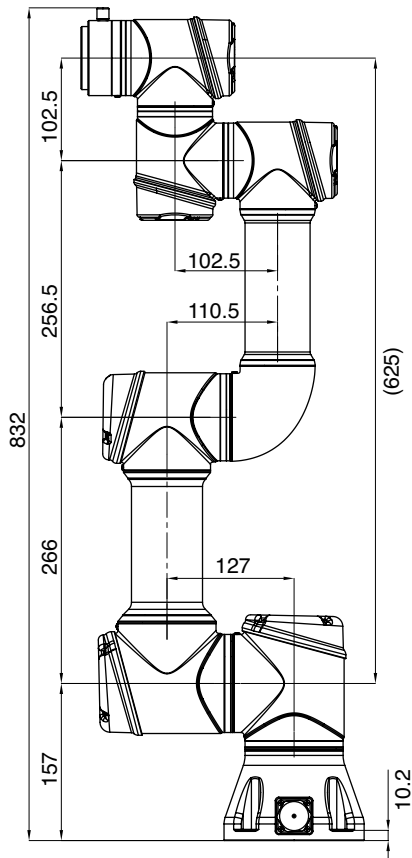



AUBO-i3

6 axis

3Kg payload

625mm reach



ROBOT SPECIFICATIONS

Degrees of Freedom	6 axes
Reach	625 mm
Payload	3 Kg
Weight	16 Kg
Dimensions	832x266x140 mm
Collaboration	Collaborative operation according to ISO 10218-1 :2001
Repeatability	+/- 0.05 mm
Linear Velocity	≤ 1.9 m/s
Power Consumption	150 W (under normal working conditions)
Materials	Aluminum, Steel, Plastic
Ambient Humidity	25% - 90%
Ambient Temperature	0 - 50° C
IP Classification	IP54
Programming	Teach pendant with user interface
Mounting Surface Diameter	∅140 mm
Motor Type	DC 48 V
Installation Orientation	Any Ceiling, Floor, Wall

AXIS MOVEMENT

J1 axis rotation base
J2 axis rotation shoulder
J3 axis rotation elbow
J4 axis wrist rotation
J5 axis wrist swing
J6 axis wrist rotation

WORKING RANGE	MAXIMUM SPEED
(+/-) 175°	180°/sec
(+/-) 175°	180°/sec
(+/-) 175°	180°/sec
(+/-) 175°	180°/sec
(+/-) 175°	180°/sec
(+/-) 175°	180°/sec

I/O PORT ON WRIST

Voltage	Current	Digital In	Digital out	Analog In	Analog Out
0/12/24 V	0.8 A	4	4	2	0

CONTROL BOX

Dimensions (LxWxH)	380x350x265 mm
Weight	15 Kg
Cabling	5 m (customizable, up to 8m)
Color	Black
Communication Interface	Ethernet, Modbus - RTU/TCP, Profinet (Optional) SDK (supports C/C++/Lua/Python) Supports ROS, API
Power supply	100 - 240 VAC, 50 - 60 Hz
IP Classification	IP43



I/O PORTS

	General I/O	Safety I/O
Digital in	16	16
Digital out	16	16
Analog In	4	-
Analog out	4	-
Output Voltage	24 V	
Output Current	3 A Max	

TEACH PENDANT

Dimensions (LxWxH)	355x235x54 mm
Weight	1.57 Kg
Display Screen	30 cm Touch LCD Screen
Cabling	4 m
IP Classification	IP43
Color	Orange



About Aubo Robotics

Aubo Robotics was established in collaboration between professors from the USA and China to make a lightweight intelligent collaborative robot. This robot arm was specially designed with important functions from the start, combining state of the art technology with user friendliness to make this a collaborative robot (Co-bot). The open source architecture enables the Robot Operating System (ROS) to be supported through an API for both industrial and academic uses.

The Aubo i Series of robots use the CAN bus networks to communicate between joints. Low cost of ownership and high positional repeatability are some of the other criteria that makes up the outstanding features of this robot. Aubo Robotics holds several core patents and has strategic cooperation with several public companies leveraging the best of all new technologies.

Robotic automation is no longer out of range for small to midsize companies. The user-friendly setup facilitates ROI in real production environments so employees without programming skills can adapt these robots for most high mix or small batch applications. Aubo looks forward to helping companies make use of this new technology and gain competitive advantage in manufacturing environment while reducing the dangerous and repetitive tasks performed by workers today.

Some places where you may see AUBO Robots:

Assembly, Packaging, Welding, Pick and Place, Inspection, Machine Tending, Pharmaceutical and Medical Labs, Research and Development, and Academia.



AUBO co-bots work closely within human environments without safety equipment, depending on risk assessment.



Applications for Collaborative Robots



Assembly



Case Polishing



Product Testing



Education



Machine Tending



Dispensing



Load/Unload



gerenga (Thailand) Co., Ltd.

945 Soi Phibun Upatham, Samsen Nok,
Huai Khwang, Bangkok 10310



www.gerenga.com

sales-asia@gerenga.com Tel: +66 (0) 2 105 4519